



ETG-5UV395-15

Package Dimensions

DESCRIPTION

SOURCE MATERIAL-----InGaN
 EMITTING COLOR-----Blue UV
 LENS TYPE-----WATER CLEAR

ABSOLUTE MAXIMUM RATING (Ta=25°C)

PEAK FORWARD CURRENT (1/10 DUTY CYCLE @ 1kHz)----100mA
 AVERAGE FORWARD CURRENT-----30mA
 LED JUNCTION TEMPERATURE-----125°C
 REVERSE VOLTAGE-----5.0V
 OPERATING TEMPERATURE----- -20°C TO +80°C
 STORAGE TEMPERATURE----- -30°C TO +100°
 LEAD SOLDERING TEMPERATURE-----260°C FOR 5 SEC.

ELECTRICAL/OPTICAL CHARACTERISTICS (Ta=25°)

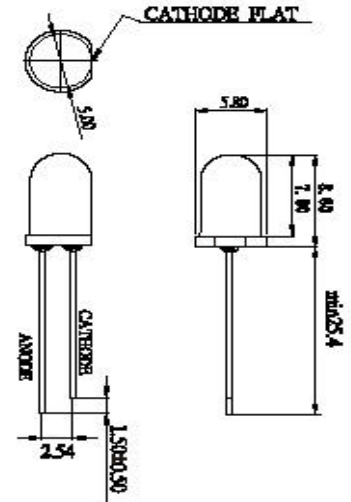

PARAMETER	CONDITION	SYMBOL	MIN	TYP	MAX	UNIT
PEAK WAVELENGTH	If=20mA	λ_D	390	395	400	nm
FORWARD VOLTAGE	If=20mA	VF		3.7	4.0	V
REVERSE CURRENT	VR=5V	Ir			10	μ A
OUTPUT	If=20mA	Iv	10	12		mW
VIEWING ANGLE	If=20mA	2 $\theta_{1/2}$		15		deg

CAUTION: EMITS ULTRAVIOLET RADIATION!!

- This device radiates intense ultraviolet (UV) light when operated.
- Exposure to UV radiation can be harmful to your health. Protect your eyes and skin during operation.
- Do not look directly at the device during operation. Exposure to UV light, even for a brief period, can damage your eyes.
- Do not operate the device unless you have had proper safety training and take appropriate precautions.
- Do not permit children or untrained personnel to operate the device.

PRECAUTIONS:

These products are sensitive to static electricity; high standard of care must be fully taken when handling them. Particularly if an over-voltage that exceeds the Absolute maximum Rating of these products were applied, the overflow energy will cause damage to and possible result in destruction of these products. Buyer shall take absolute secure countermeasures against static electricity and surge when handling these products.

ETG, Inc., 6000 Venice Bl. 2nd Floor, Los Angeles, Calif. 90034, p. 323.937.5463, f. 310.268.1766

Web: [Http://www.etgtech.com](http://www.etgtech.com) , email sales@etgtech.com