



ETG-5AX420-15 VIOLET LED

DESCRIPTION

SOURCE MATERIAL-----Ga (i) N
 EMITTING COLOR-----VIOLET
 LENS TYPE-----WATER CLEAR

ABSOLUTE MAXIMUM RATING (Ta=25°C)

PULSE CURRENT (1/10 DUTY, 0.1 mS PULSE WIDTH)-----100mA
 REVERSE VOLTAGE-----5.0V
 OPERATING TEMPERATURE----- -35°C TO 85°C
 STORAGE TEMPERATURE----- -40°C TO 100°
 LEAD SOLDERING TEMPERATURE-----260°C FOR 3 SECONDS

CHARACTERISTICS (Ta=25°)

PARAMETER	CONDITION	SYMBOL	MIN	TYP	MAX	UNIT
POWER DISSIPATION		Pd			120	mW
PEAK EMISSION WAVELENGTH	If=20mA	λ_P		420		nm
FORWARD VOLTAGE	If=20mA	Vf		3.6	4.0	V
REVERSE CURRENT	VR=5V	Ir			10	μ A
LUMINOUS INTENSITY	If=20mA	Iv	900	1000	1100	mcd
VIEWING ANGLE	If=20mA	2 $\theta_{1/2}$		15		deg

Package Dimensions

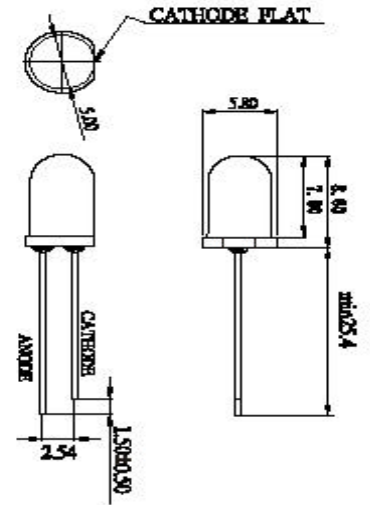

Beam Pattern

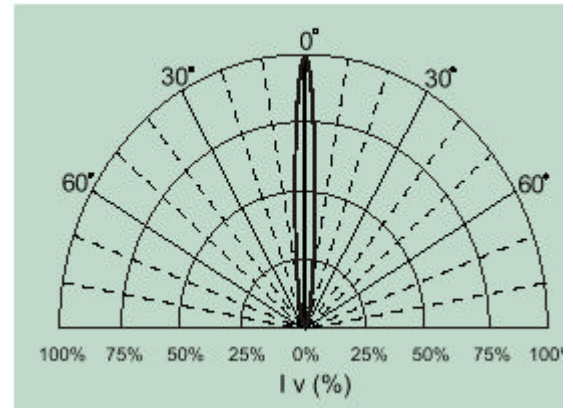

Note:

- The dominant wavelength, λ_D , is derived from CIE 1931 Chromaticity Diagram and represents the emitting color of the device.
- The luminous intensity of the lamp is measured on the mechanical axis of the lamp. The optical axis is closely aligned with the package mechanical axis.
- Less than 10% of distribution have Iv around minimum value.
- More than 70% of the distribution are within the typical value (+/- 15%)
- Specifications are subject to change without notice