



**ETG Inc.**

8599 Venice BLVD, Suite K, Los Angeles CA 90034, U. S. A.

Phone: + 1 (310) 202-6400

Fax: +1 (310) 202-6406

<http://www.etgtech.com/>

E-Mail: [info@etgtech.com](mailto:info@etgtech.com)

# **ETG-PMN525-90**

## **DATA SHEET**

QC:

ENG:

Prepared By:



**ETG Inc.**

8599 Venice BLVD, Suite K, Los Angeles CA 90034, U. S. A.

Phone: + 1 (310) 202-6400

Fax: +1 (310) 202-6406

<http://www.etgtech.com/>

Email: [info@etgtech.com](mailto:info@etgtech.com)

## Package Dimension:

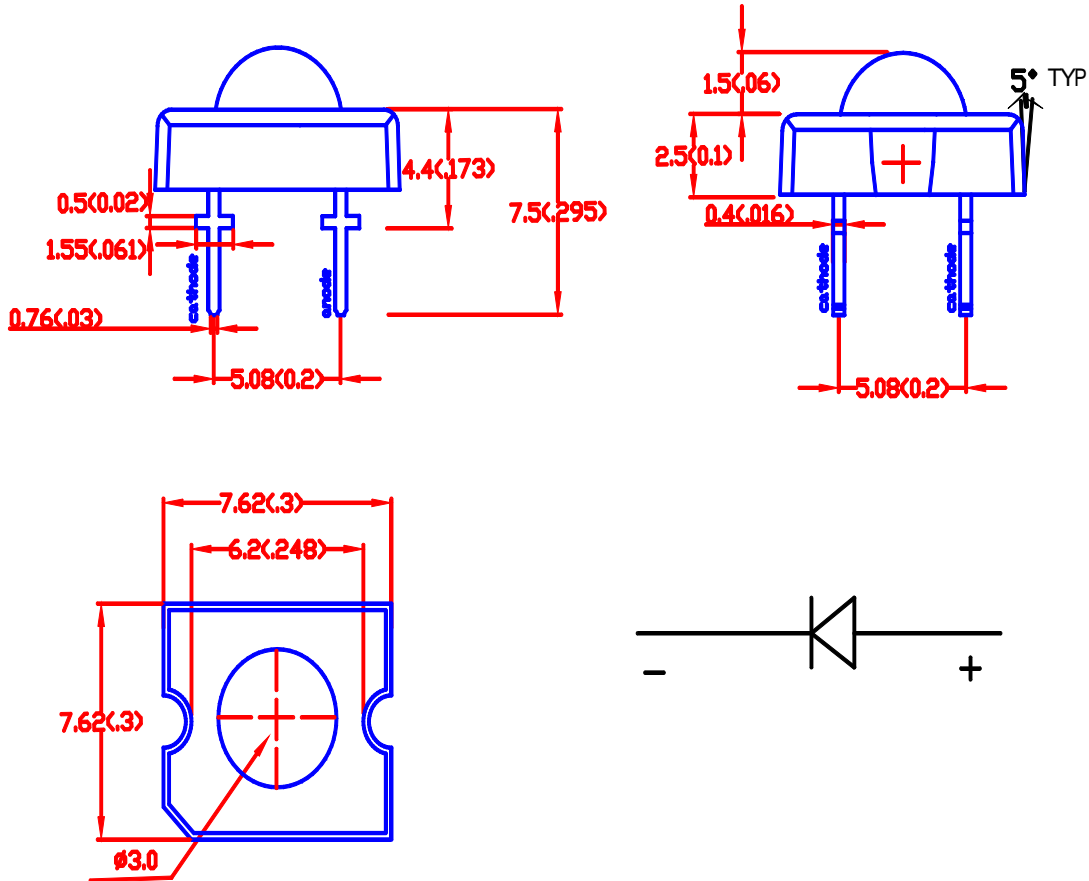

Part NO.	Chip Material	Lens Color	Source Color
ETG-PMN525-90	InGaN/SiC	Water Clear	Green

### Notes:

1. All dimensions are in millimeters (inches).
2. Tolerance is  $\pm 0.25$  mm (.010") unless otherwise noted.
3. Protruded resin under flange is 1.0mm(.04") max.
4. Lead spacing is measured where the leads emerge from the package.
5. Specifications are subject to change without notice.
6. This data-sheet only valid for six months.

**ETG Inc.**

8599 Venice BLVD, Suite K, Los Angeles CA 90034, U. S. A.

Phone: + 1 (310) 202-6400

Fax: +1 (310) 202-6406

<http://www.etgtech.com/>EMail: [info@etgtech.com](mailto:info@etgtech.com)**Absolute Maximum Ratings at Ta=25**

Parameter	MAX.	Unit
Power Dissipation	120	mW
Peak Forward Current (1/10 Duty Cycle, 0.1ms Pulse Width)	100	mA
Continuous Forward Current	50	mA
Derating Linear From 50	0.4	mA/
Reverse Voltage	5	V
Operating Temperature Range	-40 to +80	
Storage Temperature Range	-40 to +80	
Lead Soldering Temperature [4mm(.157") From Body]	260 for 5 Seconds	

**Electrical Optical Characteristics at Ta=25**

Parameter	Symbol	Min.	Typ.	Max.	Unit	Test Condition
Luminous Intensity	$I_v$	800	1200		mcd	$I_f=30\text{mA}$ (Note 1)
Viewing Angle	$2\theta_{1/2}$		90		Deg	(Note 2)
Peak Emission Wavelength	$\lambda_p$		525		nm	$I_f=20\text{mA}$
Dominant Wavelength	$\lambda_d$		523	530	nm	$I_f=20\text{mA}$ (Note 3)
Spectral Line Half-Width	$\lambda$	15	20	25	nm	$I_f=30\text{mA}$
Forward Voltage	$V_f$		3.2	4.0	V	$I_f=30\text{mA}$
Reverse Current	$I_R$	---	---	100	$\mu\text{A}$	$V_R=5\text{V}$

**Notes:**

1. Luminous intensity is measured with a light sensor and filter combination that approximates the CIE eye-response curve.
2.  $\theta_{1/2}$  is the off-axis angle at which the luminous intensity is half the axial luminous intensity
3. The dominant wavelength ( $\lambda_d$ ) is derived from the CIE chromaticity diagram and represents the single wavelength which defines the color of the device.



# ETG Inc.

8599 Venice BLVD, Suite K, Los Angeles CA 90034, U. S. A.  
Phone: + 1 (310) 202-6400 Fax: +1 (310) 202-6406  
<http://www.etgtech.com/> EMail: [info@etgtech.com](mailto:info@etgtech.com)

## Typical Electrical / Optical Characteristics Curves (25 Ambient Temperature Unless Otherwise Noted)

Spectral Radiance (Peak @525nm)

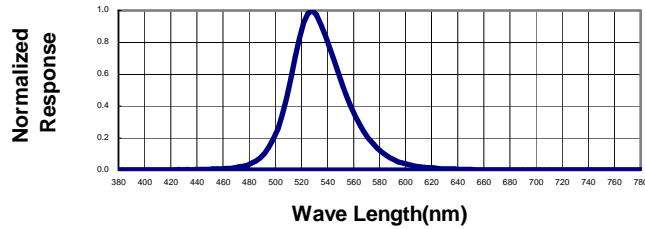

Forward Current vs Forward Voltage

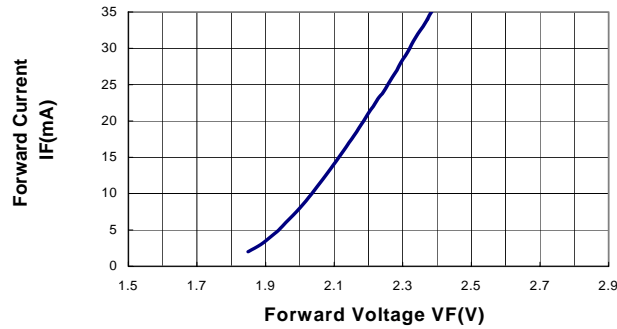

Relative Luminous Intensity vs Forward Current

